

ULTRA-ZONE®

Forced Air Zone Controls

MODEL ND Series Dampers

Construction-
Heavy Duty extruded aluminum.

Nylon Bearings for quiet operation.

Overlapping parallel blades for low leakage.

Power open/Power closed.

Designed to operate at static pressures up to 1.5"
w/ less than 5% Leakage.

UL Listed Motor Actuator is a 24vac 3 wire power
open/power close type rated at 18"lbs. of torque.

NEMA1 Rated Housing.

End-Stops for Min/Max Travel Adjustments.

LED's Indicate damper position.

Available in 8" x 6" thru 30" x 30" in one inch
increments. Custom Sizes can be manufactured,
contact EWC Controls Inc.

SUBMITTAL SHEET

Model ND
w/ MA-ND4 Actuator

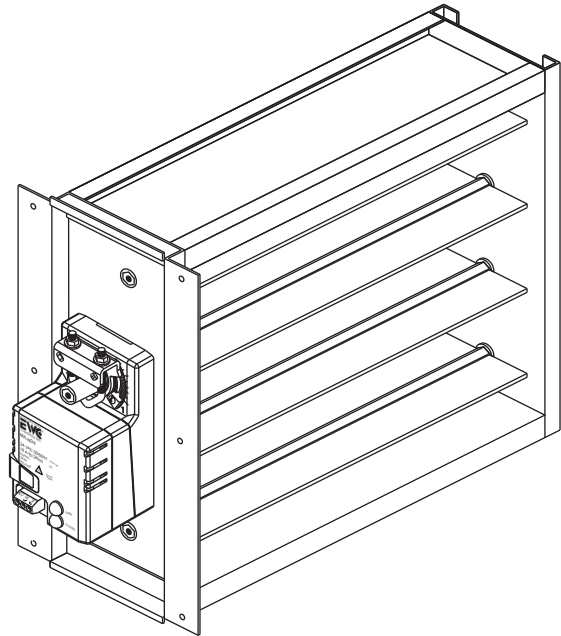

DIMENSIONAL
DRAWINGS

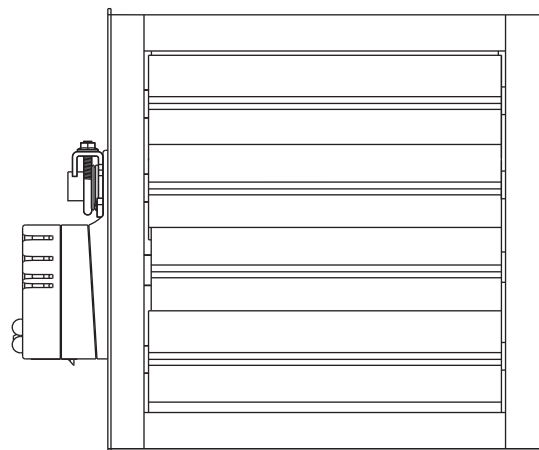
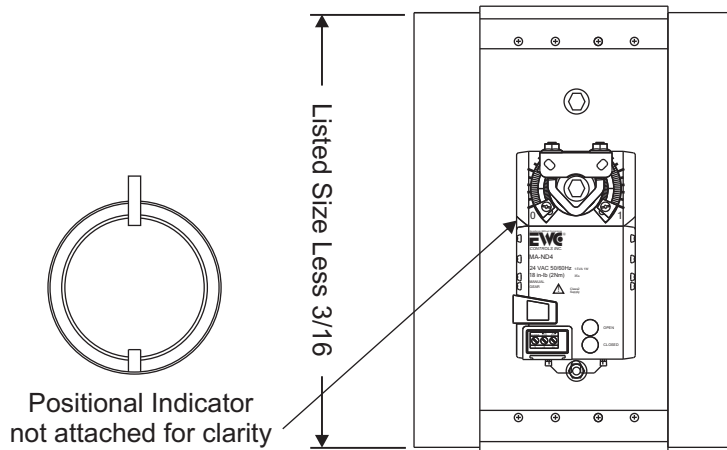
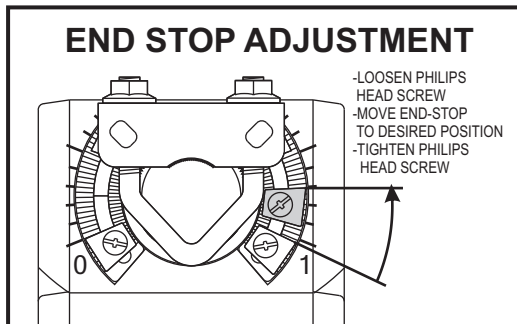
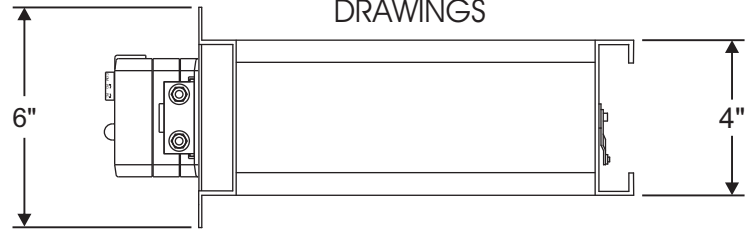

SUBMITTAL FORM

SUBMITTED BY: _____
 JOB: _____
 ARCHITECT: _____
 ENGINEER: _____
 CONTRACTOR: _____
 LOCATION: _____

Excellence Without Compromise



385 Hwy. 33
 Englishtown, NJ 07726
 Ph: 800-446-3110
 Fx: 732-446-5362

P/N 090377A0071 REV. L

Copyright © EWC Controls 2005-2008 All Rights Reserved

Insertion Mounting

Cut a 4" slotted opening in one side of the duct and slide the damper in. Secure the damper to the duct with the supplied sheet metal screws. Larger sizes may require additional support by securing the back of the damper as well. If using duct board, additional support can be obtained by using Model DBA Duct Board Adaptors.

**If flush wall mounting is required, cut the flanges off of the front mounting plate.*

WIRING SOLUTIONS

MOTOR Terminal Output

- M6 - Power to Close (PC)
- M4 - Power to Open (PO)
- M2 - Constant Power (HOT)
- M1 - Common (COM)

Wiring to a Control Panel

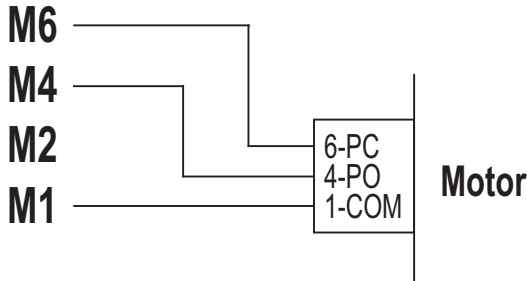

Wiring a Thermostat to Control a Single Damper

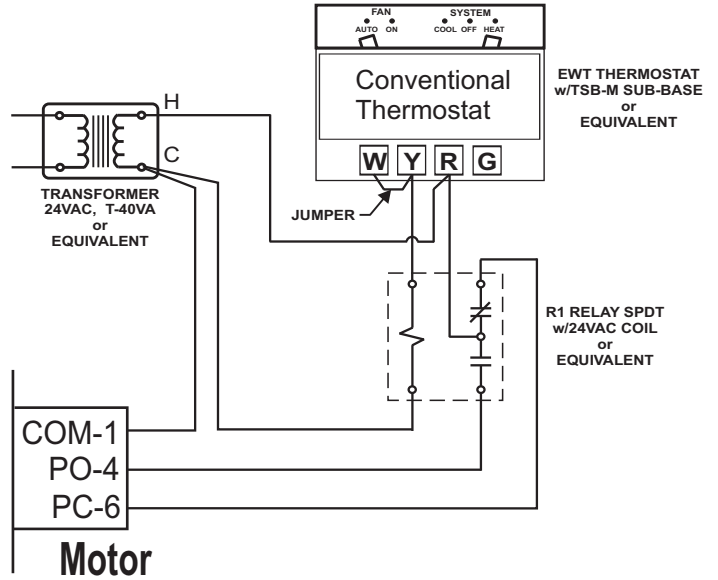

Wiring in Parallel

